

IB-500 FOUNDATION ISOLATION SYSTEM

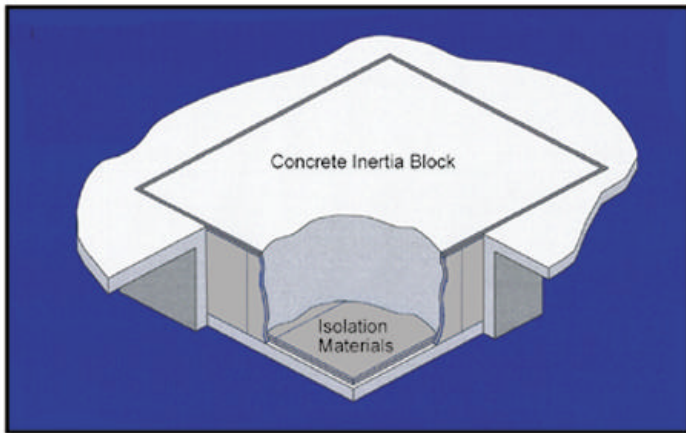

The Unisorb IB-500 system is the simplest to install of all approaches. With a natural frequency in the 8 to 19 Hz range, the IB-500 system is capable of serving the majority of industrial applications very well. It consists of a concrete inertia block sized to provide adequate support for the machine being installed. It also supplies sufficient mass to give needed damping to the system being supported by Unisorb's IB-500 series foundation isolation pad materials. Unisorb will help with the final design of this system to assure that maximum performance is achieved.

There are basically three construction methods to choose from when installing Unisorb IB-500 materials. The following descriptions and illustrations will address these in detail.

- **Materials placed in Excavated Pit**
- **Casting a Concrete Lined Pit in which to place isolation materials**
- **Oversize Excavation which allows sidewall backfill**

Excavated Pit

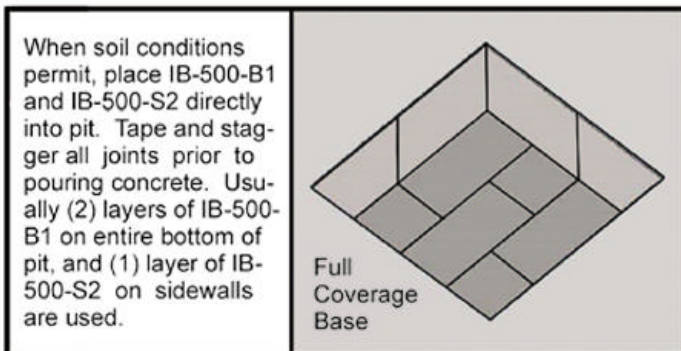

IB-500 foundation isolation pad materials are suitable for direct exposure to wet concrete, however the joints must be sealed with Unisorb IB-500 Seam Tape to prevent the incursion of fluid concrete during pour. It is also advisable to place a Unisorb Poly Pit Liner inside the lined pit to assure that no "short circuits" occur.

In some cases it is necessary to provide "Partial Coverage" on the base of a foundation due to a need to achieve a higher pad loading and resultant lower natural frequency than is possible with full coverage. The following illustration depicts this.

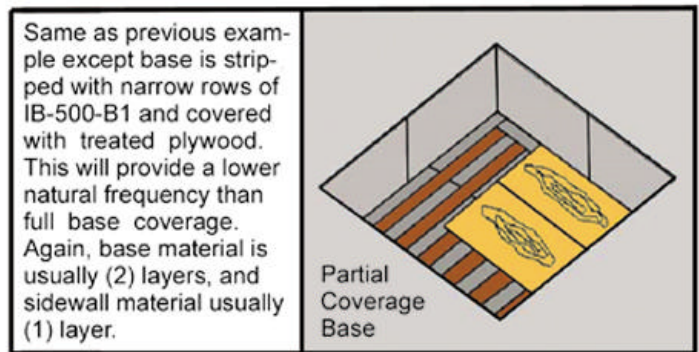

A mud mat is poured, then rows of base isolation material are placed, with the air gap integrity protected by sheets of treated plywood. This allows more weight to be concentrated on the base material, thus driving the pad loading up and the natural frequency down.

Sometimes it becomes necessary to use more than (2) layers of base and (1) layer of sidewall material. This is true for either full or partial coverage designs. This is done to fine tune the natural frequency of the foundation to suit the needs of the specific installation.

Following are some photos taken of an actual excavated pit installation.



Note the exposed soil of the sidewall in this photo. Soil conditions at this location permitted a straight, smooth sidewall to be dug with minimal effort. Also note that the sidewall materials are taped to the concrete floor surface to hold them in place.



Here a mud mat is poured, then IB-500-B1 base material is applied in strips to achieve the desired pad loadings. In the foreground a sheet of treated plywood is being installed to protect the integrity of the spaces between the strips of base material (to prevent fluid concrete from entering the spaces). Notice that there is a strip of IB-500-B1 material around the perimeter of the base of the foundation as well as across (the full length).

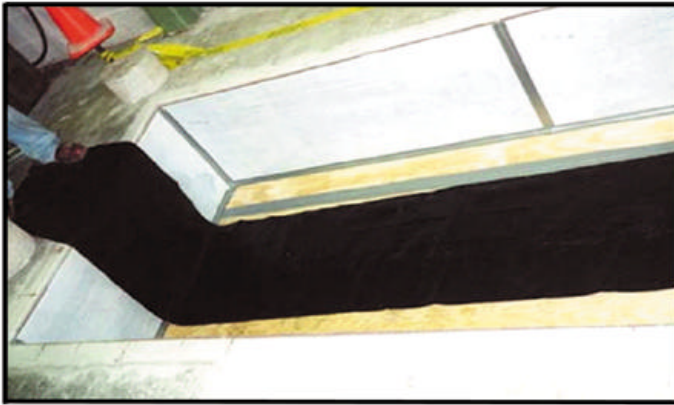

In this photo a Unisorb Poly Pit Liner is being installed over the treated plywood sheeting.



Here we have another view of the same foundation ready for the placement of the reinforcing steel and concrete.

Concrete Lined Pit

When soil conditions require, or when using partial coverage base, form and cast in place a concrete lined pit. Place IB-500 materials inside, using either full or partial coverage as addressed in previous illustrations.

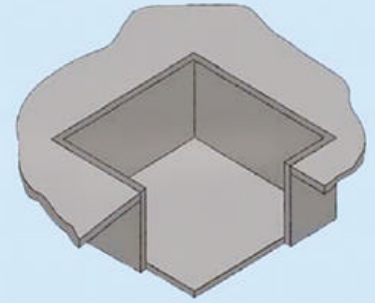

This method of construction is used where soil conditions are less than ideal, or when it is desirable to provide a positive seal against contaminants reaching the sub soil. This creates a "socket" for the isolation material and inertia block foundation to be placed.

Following is a photograph showing a Concrete Lined Pit type foundation taken on an actual job site.



In this instance a concrete lined pit has been prepared due to less than ideal soil conditions. Note the "stepped" construction to establish the desired machine height.

Oversize Excavation

After pouring foundation in oversize pit, apply IB-500-S2 to sidewalls and backfill. Compact soil and complete concrete work to joint.

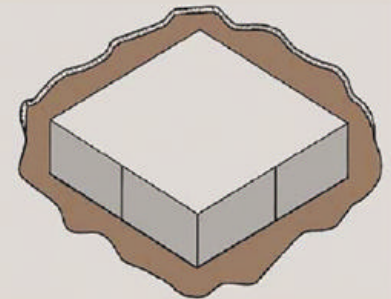

The third acceptable method for installing Unisorb IB-500 materials is to dig an oversize pit. Here the foundation is poured directly on the IB-500-B1 base isolation material using removable forms to contain the perimeter. Once sufficiently cured, the sidewall forms are removed, and the isolation material is applied to the sidewalls. The pit is then backfilled directly against the IB-500-S2 sidewall material. This method is very cost effective when sufficient clearance is available to permit the larger excavation.

***Prior to Pouring Concrete Checklist
(All three methods)***

- All seams to be taped with Unisorb IB-500 Seam Tape
- Do not puncture or bridge IB-500 pad materials with fasteners of any type
- Install Unisorb Poly Pit Liner after the IB-500 materials are in place
- Support re-bar with load spreading chairs or blocking materials

Floor Level Joint Treatment

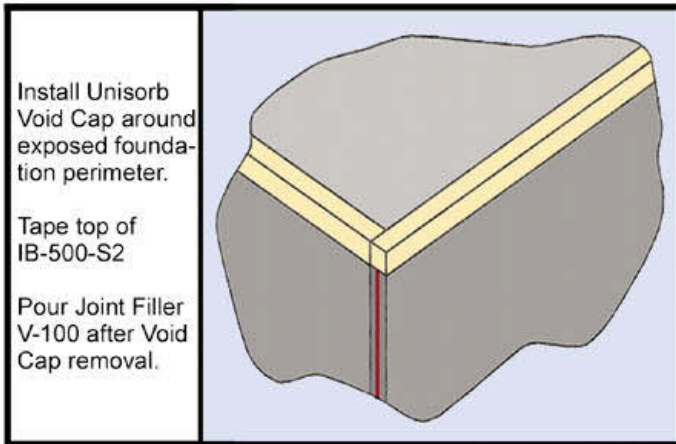

In all installations a sealed joint at floor level is desired. The sidewall material is placed 1/2" below the surface of the concrete, and a Unisorb Void Cap strip is inserted to create a pre-formed space for the application of Unisorb Joint Filler V-100 material. This material comes in a two part kit, and is simply mixed at the job site and poured into the channel created by the removal of the Void Cap strip after the concrete has sufficiently cured. The Joint Filler V-100 material is highly resilient, and colored gray to match the surrounding concrete.

***IB-500 Pad Material Availability
(All three methods)***

The IB-500 pad materials are supplied in 36" x 72" sheets to be cut-to-fit on the job site. In the case of partial coverage base type designs, 6" or 12" wide x 72" long strips of IB-500 base material may be supplied.

Unisorb's IB-500 isolation pads have been tried and proven in thousands of applications worldwide, and passed the test of both time and performance with flying colors. Consult with our Engineers about your application.