

UNISORB® RK FIXATOR® ANCHORING/ALIGNMENT SYSTEM

NOTE: All Fixator information in this catalog pertains to machine tool applications. Call UNISORB about the use of Fixators for Power Generation equipment.

RK FIXATOR SYSTEMS level and align machinery to tolerances of one ten thousandth (0.0001") and make it possible to vary adjustments at any time, even under maximum loads requiring only a small hand wrench to adjust. Time consuming work and production losses normally associated with alignments are eliminated.

While affording **the most rigid machine-to-foundation connection available**, other benefits include built-in compensation for uneven areas in foundations and machine bases. True vertical lift, made possible by a 3-piece wedge design to eliminate lateral movement as machines are raised or lowered, makes the RK FIXATOR the "state-of-the-art" anchoring/alignment system.

INTEGRATED SYSTEM DESIGN

Though similar in appearance to conventional wedge-type leveling equipment, RK FIXATOR SYSTEMS differ significantly in concept and application. The RK FIXATOR is not a conventional wedge system and should not be treated as one. **Alignment adjustments are made after anchor nuts have been tightened.** In this way, the anchor bolts are tightened uniformly to predictable stress levels by adjusting the RK FIXATOR basic unit upward prior to the final alignment procedure eliminating the customary torquing of anchor nuts. This gives substantial savings in time and effort normally required for the installation of sophisticated machine tools.

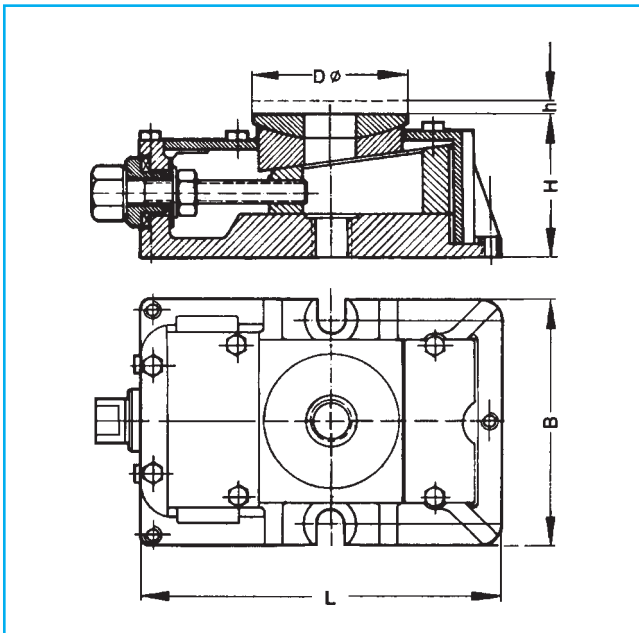
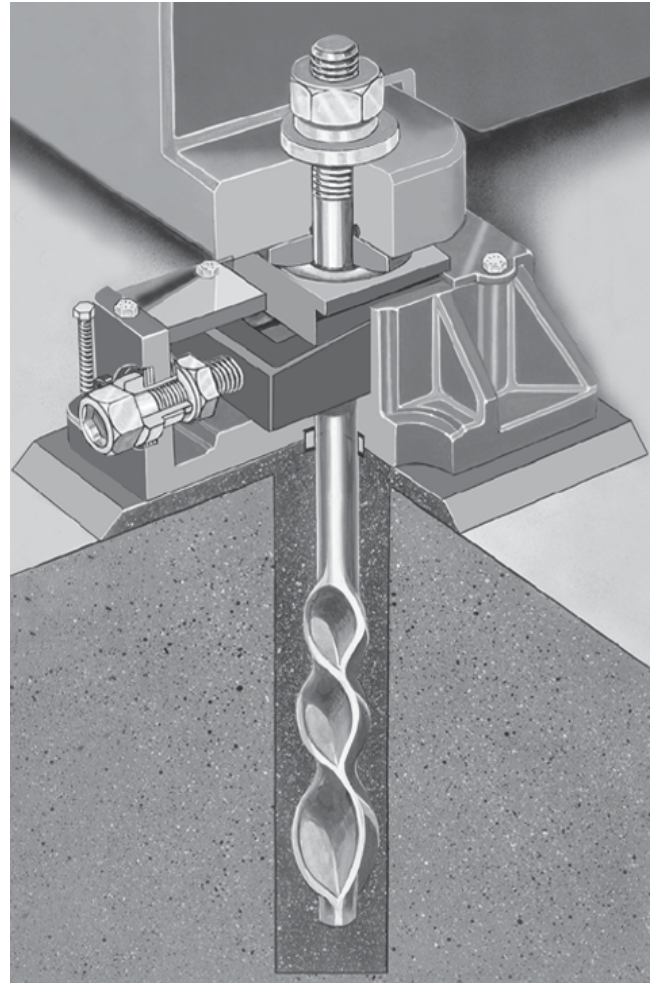

RK FIXATORS SAVE MONEY BY:

- Allowing faster completion of new installations.
- Decreasing frequency of, and shorten time required for future realignments.
- Maintaining machine accuracy for longer time periods.
- Decreasing required maintenance.
- Ensuring maximum machine productivity.

BASIC DIMENSIONS					
Dimension	RK I	RK II	RK III	RK IV	RK V
Dø	2.36	2.95	3.54	4.33	5.91
L	6.89	7.01	8.66	10.83	13.58
B	4.13	4.72	5.91	7.09	9.06
H	2.17	2.95	3.74	4.53	5.31
h	.20	.20	.24	.32	.40

LOAD RANGES (PER MOUNT)		
MODEL NO.	*RECOMMENDED MACHINE STATIC WEIGHT	MAXIMUM ALLOWABLE LIFTING LOAD
RK I	2,200 lbs.	20,000 lbs.
RK II	4,400 lbs.	26,500 lbs.
RK III	8,800 lbs.	53,000 lbs.
RK IV	13,200 lbs.	80,000 lbs.
RK V	26,400 lbs.	155,000 lbs.

*Contact Unisorb Engineering for application assistance.